

Side By Side and Stacked (1 over 1) Replacement Impact Mulling

Part Number	AMI Part Number	Quantity	Description
1	UL-0058-01/23	1	Aluminum Mullion
2	US-0180-XX	2	Replacement Bracket (goal Post)
3	UZ-0058-00	4 PER MULL	8 X1/2 PPH TEK sst
4	UZ-0041-00	2 Packs	Bracket Anchor screw pack #8 x 2-1/2" screws
5	UZ-0110-01/23	8 PER MULL	1" PPH tek screw

Instructions:

Step 1: Pre-drill the face of the 2 brackets using a 3/16" drill bit, so that the bracket can accept *part #4*. **See Fig B** (Typical hole pattern).

Step 2: Insert Goal Post bracket into the hollow of the mullion and bring this assembly into the opening. Slide the brackets up so that they mate with the head and sill of the opening. Make sure that the mullion is plumb and level; using *part #4* screw through the bracket and into head end of the opening. **See Fig B** Repeat this procedure for the Sill.

Step 3: Drill through the center the mullion and approximately 1" down from the head using a 1/8" drill bit, through the mullion and one of the bracket legs. Using *part #3*, Screw through the mullion and and the bracket leg. **See Fig C**. Repeat procedure for both sides and for sill end.

Step 4: Install one window into the opening, making sure that the window is plumb and level. At a point that is 3" below the head of the frame and in the center of the interior jamb track, secure the window using *part #5* by screwing through the window frame and through the mullion. Repeat this process 2" above the center of the window. **See Fig A**.

Step 5: In the Exterior jamb track, approximately 3" from the bottom of the sill and 11/16" from the exterior frame edge, drill a 1/8" hole through the frame and mullion, Next utilizing the 1/8" pilot hole, drill through 2 walls of the frame with a 1/2" drill bit. **See Fig D and E**. Secure the window to the mullion using *part #5* and install a hole plug supplied with the window.

Step 6: Caulk all all exposed joints.
Repeat Steps 4, 5 and 6 for adjacent windows.

The instructions for the Stacked Mull are exactly the same, except the mullion is rotated 90 degrees.

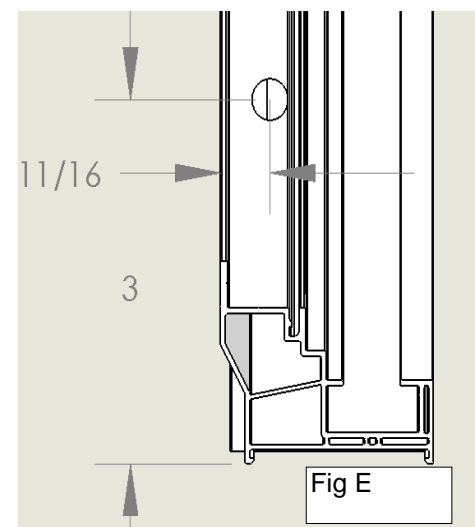
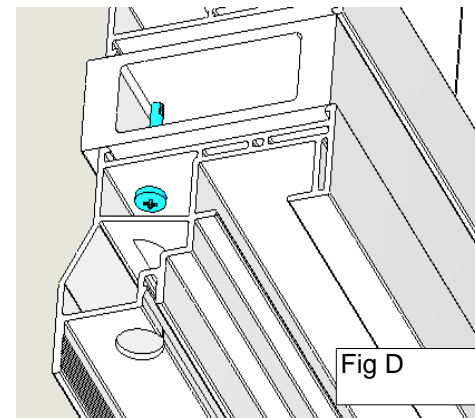
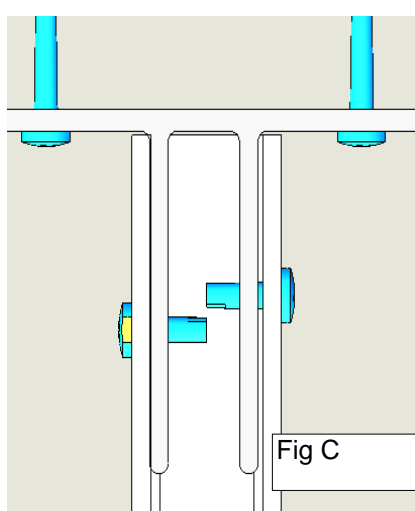
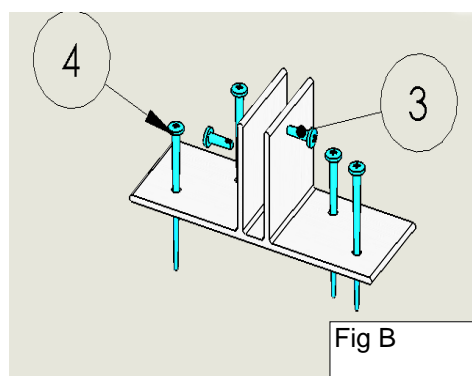
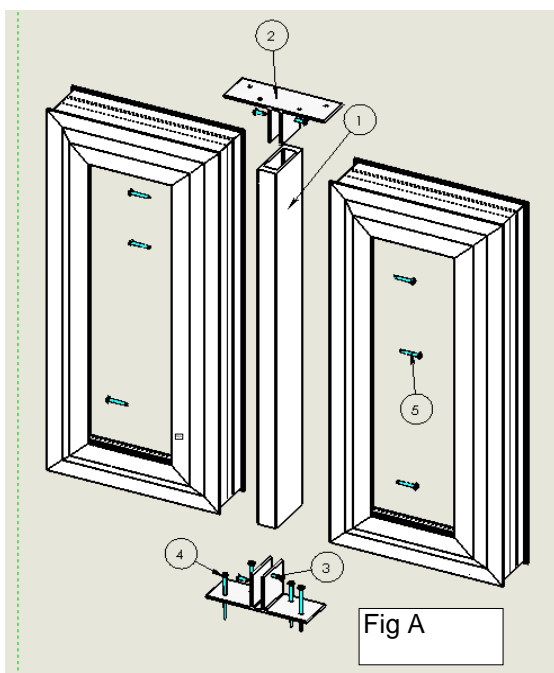

Side By Side and Stacked (1 over 1) New Construction Impact Mulling

Part #	AMI Part #	Quantity	Description
1	UL-0058-01/23	1	Aluminum Mullion
2	US-0180-XX	2	Replacement Bracket (goal Post)
3	UZ-0058-00	4 PER MULL	8 X1/2 PPH TEK sst
4	UZ-0041-00	2 Packs	Bracket Anchor screw pack #8 x 2-1/2" screws
5	UZ-0110-01/23	8 PER MULL	1" PPH tek screw
6	UK-0163-01/23	8 PER MULL	J Channel Drip Cap
7	UK-0157-01/23	8 PER MULL	J channel Extender (Trim Clean)
8	US-0181-XX	8 PER MULL	Bull Nose Bracket

Please follow basic Installation procedures for Replacement Side by side Version; New Construction has the following exceptions.

Remove this leg

Nail fin needs to be cut out slightly larger than the bracket. This is done at all joints, (Head and Sill). Prior to Install

At the head end of the Window remove this leg with a utility knife, on the head end of the window, prior to install. This is so Part #6 will onto the head.

Install Bull Nose Bracket at the Head only. The Goal post is installed at the Sill.

Install screws as shown into the head of the opening using Part #4

Once the mullion and windows are in place the balance is finishing the window with trim.

5

Trim Clean J channel Extender Part 7. Snaps on to J channel

Before Trim

After Trim Clean

Install J Channel drip Cap to the head of window. When installing make sure to cut a tab into the side of the drip cap so that it folds over the jamb edge, this will seal the

These are assembly procedures for mulling please make sure to follow all of the caulking and flashing details for the Windows.

Tee Mull for Replacement Impact Mulling

Part #	AMI Part #	Quantity	Description
1	UL-0058-01/23	2	Aluminum Mullion
2	US-0180-XX	4	Replacement Bracket (goal Post)
3	UZ-0058-00	4 PER MULL	8 X1/2 PPH TEK sst
4	UZ-0041-00	3 packs	Bracket Anchor screw pack #8 x 2-1/2" screws
5	UZ-0110-01/23	8 PER MULL	1" PPH tek screw
6	UU-5165-XX	With Window	Hole Plug (with Impact window)

Instructions:

Step 1: Pre-drill the face of the 3 brackets (Sill bracket and side brackets) using a 3/16" drill bit, so that the bracket can accept part #4. **See Fig A** (Typical hole pattern).

Step 2: Install the Vertical Mullion with bracket and secure into position. Positioning is based on window sizes, (typically the mullion is in the center of the opening). Using part #4 anchor the bracket onto sill. Do not install side screws Part #3 at this time. **See Fig B**

Step 3: Temporary Set up Bring one window into the opening; shim so that window is plumb and level against the mullion. Install a bracket at the top of the mullion so that it is tight to the mullion end; measure from the top of the bracket to the top of the frame. This is how much will be needed to be cut off the mullion to form a tight fit. Cut the mullion to the proper finished height. **See Fig C&D.** Remove the dry fit window and proceed to step 3.

Step 3: Reinstall the mullion on the bracket secured to the sill. Using a 1/8" drill bit, drill through the mullion and 1 leg of the bracket. Using part #3, secure mullion to the bracket leg. Repeat for the adjacent side. The location is approximately 1" above the mullion end and in the center; the opposite side should be slightly off center so that screws do not have any interference. **See Fig E**

Step 6:

6A) Reinstall one window into the opening; at this point you will be securing the window to the jamb of the rough opening. The window is installed by using the # 10 x2" screws supplied with the window (consult window instructions for jamb installation). Make sure that the window is plumb and level; shim as needed.

6B) At a point that is 3" below the head of the frame and in the center of the interior jamb track, secure the window using part #5 by screwing through the window frame and through the mullion. Repeat this process 2" above the center of the window. **See Fig Explode.**

6C) In the Exterior jamb track, approximately 3" from the bottom of the sill and 11/16" from the exterior frame edge, drill a 1/8" hole through the frame and mullion, Next utilizing the 1/8" pilot hole, drill through 2 walls of the frame with a 1/2" drill bit. **See Fig F and G.** Secure the window to the mullion using part #5 and install a hole plug supplied with the window. Install the opposite window side window, utilizing steps 6A, 6B and 6C.

Step 7: Once windows are installed at this point they are stable and level; slide in the top bracket into the mullion; Bring horizontal mullion with the 2 brackets and install into the opening so that it touches the head of the window frame to form the TEE. Secure the top half of each side bracket to the opening. **See Fig H**

Step 8: On the furthest jamb side and at a point 1" below the inside of the window head and in the interior track; drill two 3/16" holes through the window frame and through bracket the second should be slightly above the initial hole. Screw through the frame, bracket and into the window opening for both holes using part # 4. **See Fig I** Repeat with opposite window.

Step 9: Install the transom window into the opening by securing the window with #10 x2 truss head screw that are supplied with the window. Do this for the jambs and the head of the window at this time.

Step 10: Securing the sill at the horizontal mull. Now that the window is in the opening secure the sill by drilling 3/16" hole approximately 1" from the inside edge of the transom through the frame (not the mullion). Using the 3/16" hole as a pilot drill a 1/2" hole through the first wall of the frame. Secure by using part # 5 and screw the frame and into the mullion. Seal the hole with a hole plug provided with the window, part #6. Repeat for both sides **See Fig J.** Secure the bottom windows to the horizontal mullion by drilling two 3/16" holes at 1" and 3/4" from the inside jamb and up through the head, repeat for opposite window. **See Fig K**

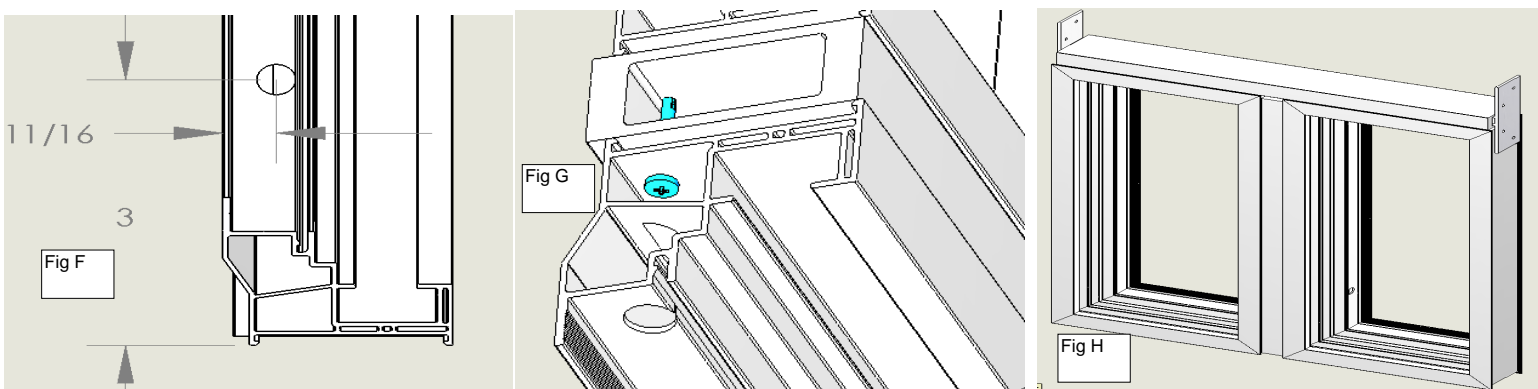
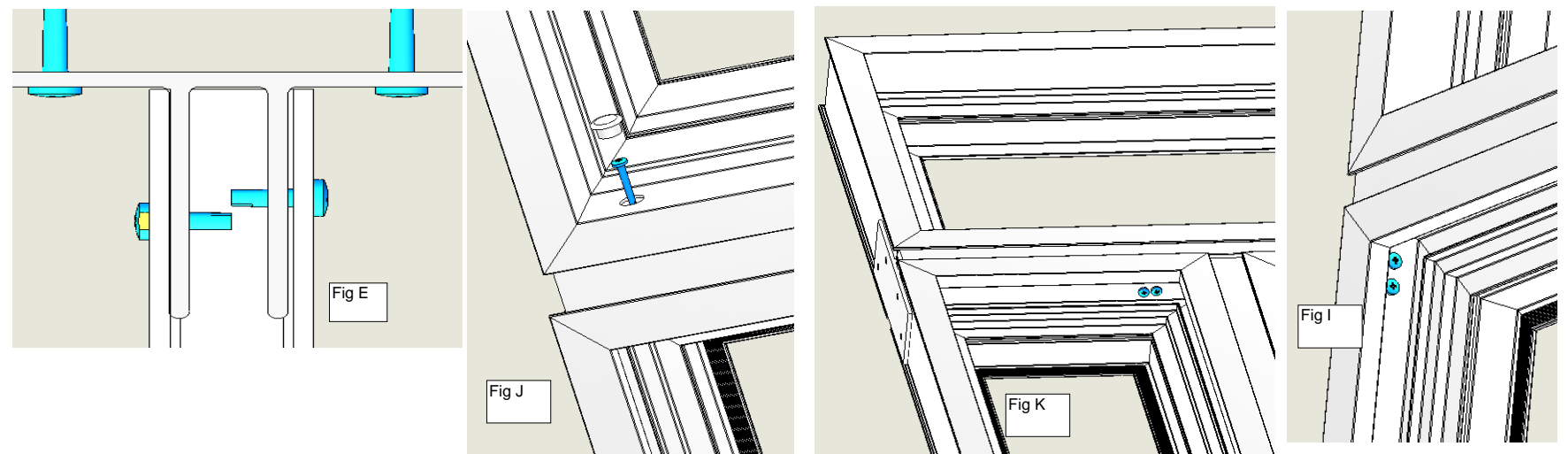
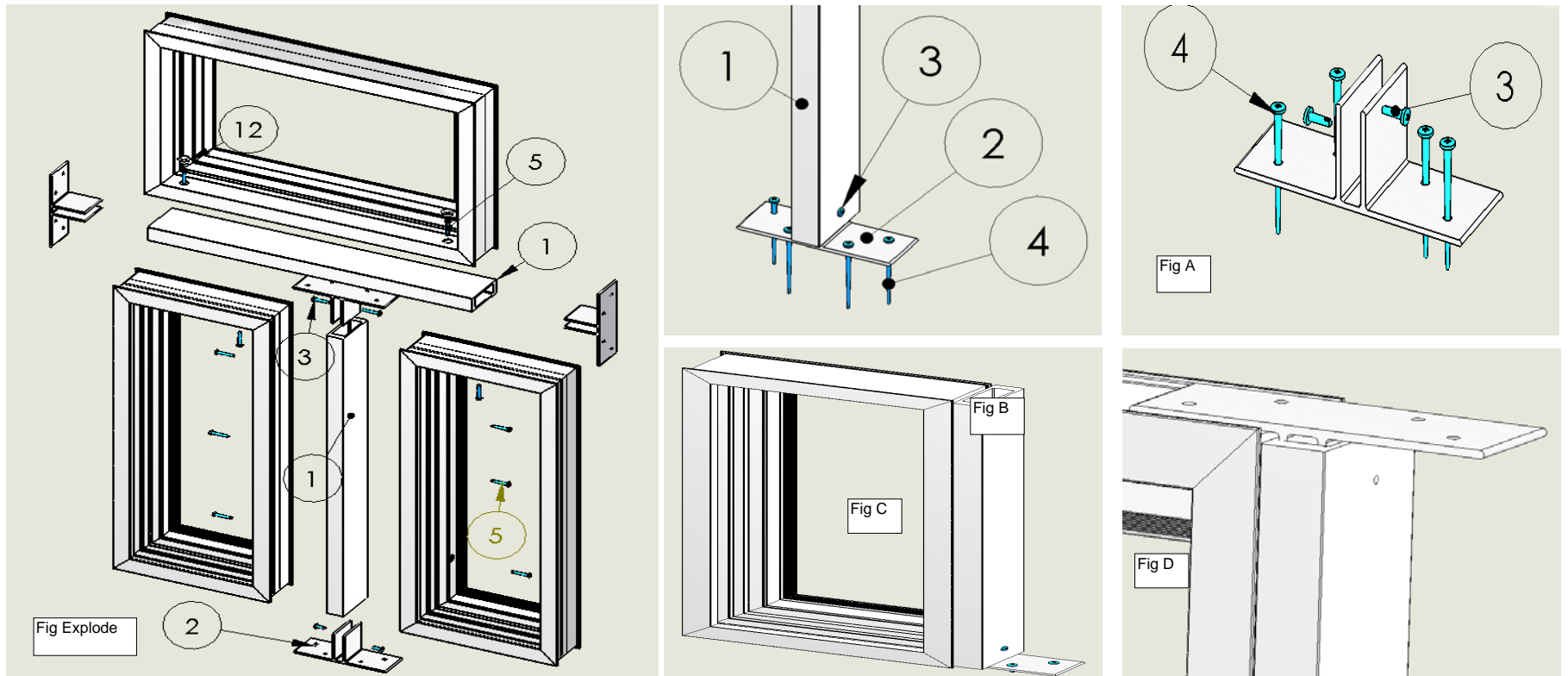

Tee Mull for New Construction Impact Mulling

Part #	AMI Part #	Quantity	Description
1	UL-0058-01/23	2	Aluminum Mullion
2	US-0180-XX	4	Replacement Bracket (goal Post)
3	UZ-0058-00	4 PER MULL	8 X1/2 PPH TEK sst
4	UZ-0041-00	3 packs	Bracket Anchor screw pack #8 x 2-1/2" screws
5	UZ-0110-01/23	8 PER MULL	1" PPH tek screw
6	UU-5165-XX	With Window	Hole Plug (with Impact window)
7	UU-5165-XX	With Window	Hole Plug (with Impact window)

Below are pictures of an additional part and processes that are added to the New construction Tee Mull. Please refer to the Replacment Tee Mull procedures.

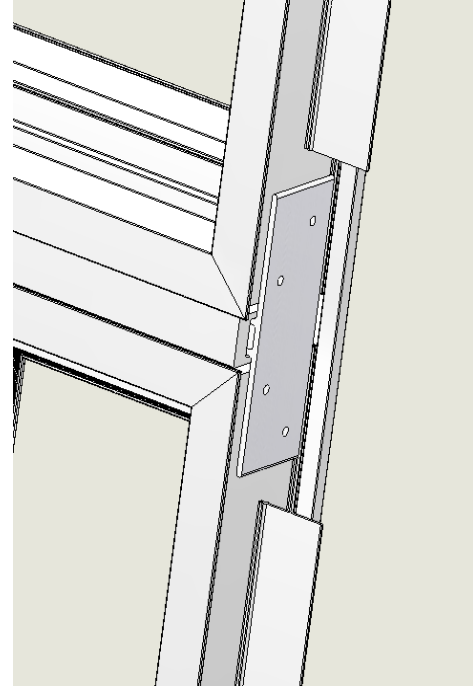
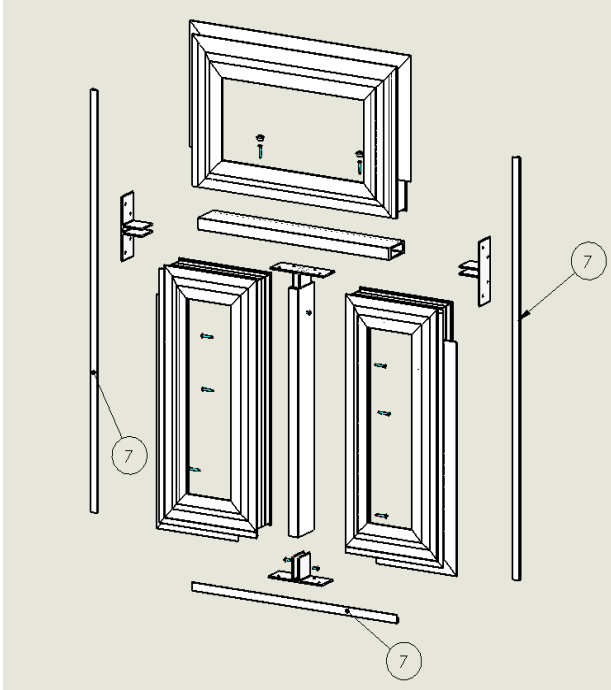

Nail fin needs to be cut out slightly larger than the bracket. This is done at all joints, (sill and jambs).

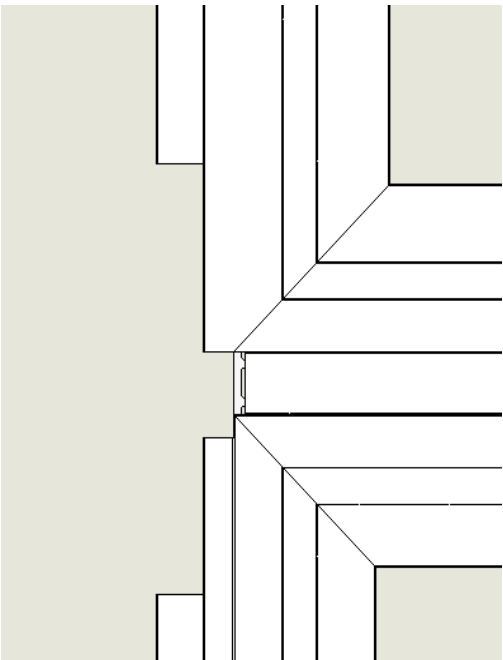

Before trim Clean

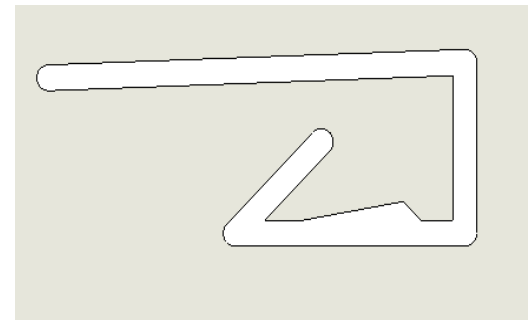

J channel trim extender (Trim Clean)

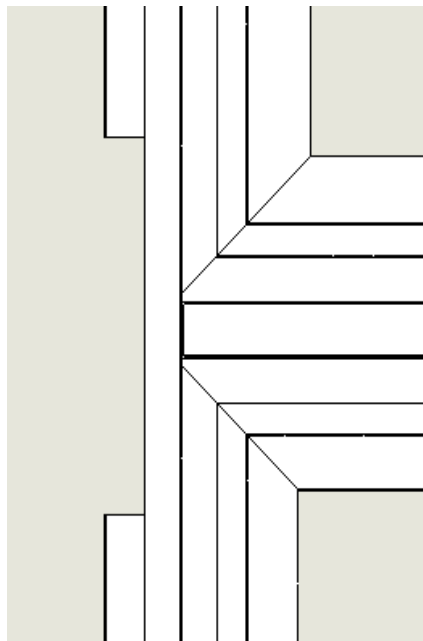

After trim Clean

These are assembly procedures for mulling please make sure to follow all of the caulking and flashing details for the Windows.

Stacked New Construction Impact Mulling

Part #	AMI Part #	Quantity	Description
1	UL-0058-01/23	1	Aluminum Mullion
2	US-0180-XX	2	Replacement Bracket (goal Post)
3	UZ-0058-00	4 PER MULL	8 X1/2 PPH TEK sst
4	UZ-0041-00	2 Packs	Bracket Anchor screw pack #8 x 2-1/2" screws
5	UZ-0110-01/23	8 PER MULL	1" PPH tek screw
6	UK-0157-01/23	8 PER MULL	J channel Extender (Trim Clean)

Please follow basic Installation procedures for Replacement Side by side Version; New Construction has the following exceptions.

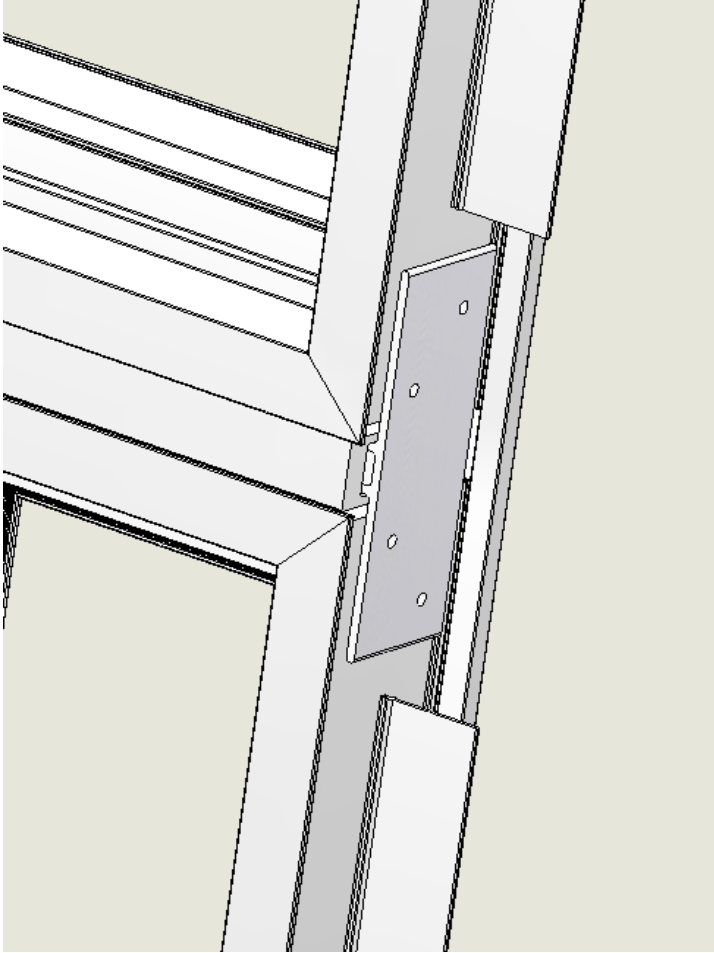

Nail fin needs to be cut out slightly larger than the bracket. This is done at all joints, (jambs).

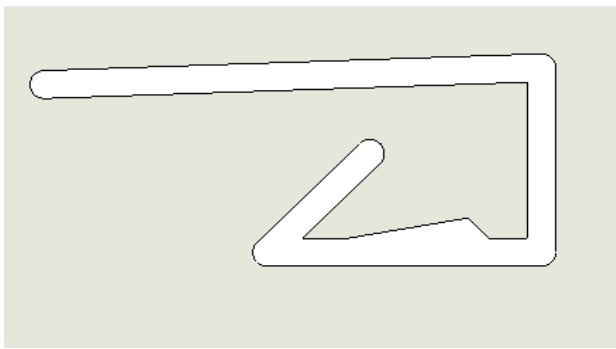

J channel trim extender (Trim Clean)

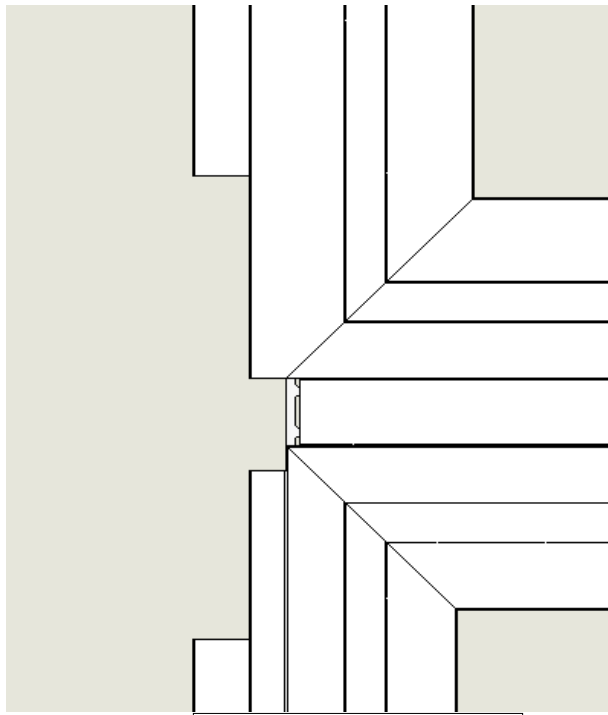

Before trim Clean

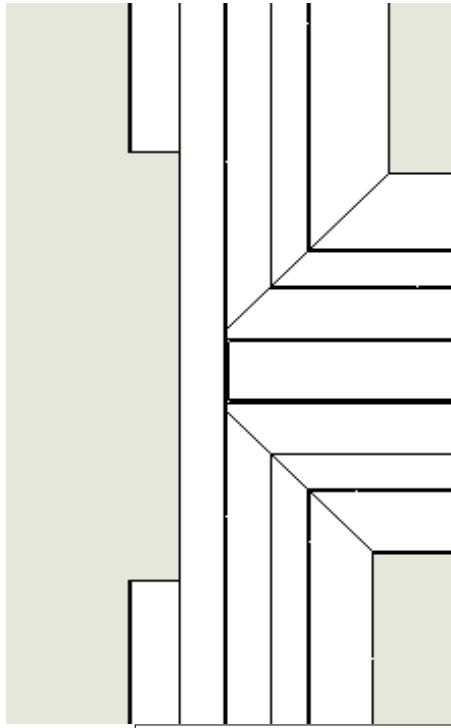

After trim Clean

These are assembly procedures for mulling please make sure to follow all of the caulking and flashing details for the Windows.